

COLUMBIA COUNTY FIRE SERVICES
FIRE APPARATUS ACCESS ROADS & DRIVEWAYS STANDARD

5.0 INTRODUCTION:

This Standard shall apply within all areas of Columbia County. It is the purpose of this Standard to foster unity of understanding in areas where there may be difficulty in understanding the intent of the International Fire Code, hereafter referred to as the Oregon Fire Code, as well as promote the public's health, safety and welfare through the installation and regulation of fire apparatus access roads and driveways as required by the Oregon Fire Code, Chapter 5 and Appendix D.

The Columbia County Fire Services have the authority and responsibility to process requests for review and approval of all fire apparatus access roads and driveways. Outside Rural Fire District boundaries, the applicable district Ambulance Service Area boundary shall be recognized as the area of responsibility for that district's access consultation and approval.

5.1 DEFINITIONS:

All Weather Driving Surface: A firm, uniform road surface designed and maintained to bear the imposed loads of fire apparatus.

Cul-de-sac: A permanently maintained, clear, unobstructed road space at least 96 feet in diameter at the end of a dead-end street.

Curb: A border forming part of a gutter along the edge of a street or bridge.

Driveway: All driveways will require a 12' wide firm, uniform all weather road surface with a clear and unobstructed 20' right of way. Can be used when there are "not" more than two (2) Group R, Division 3 (private dwellings) served.

IFC Chapter 5
Access Roads/Driveways
Approved Date

Fire Apparatus Access Road: A required road which is at least twenty (20) feet wide, has a firm, uniform all weather road surface with an unobstructed height of 13'6" which is used by fire apparatus and other vehicular traffic.

Grade: The percent of inclination of a slope, road, or driveway.

Turnaround: A permanently maintained, clear, unobstructed road space used for turning around fire apparatus.

Turnout: A section of road wide enough to permit the passing of two vehicles.

Street Intersection: Place where two or more roads cross.

5.2 FIRE APPARATUS ACCESS ROADS:

Fire apparatus roadways shall be provided so that no portion of an exterior wall of the first story is located more than 150 feet from an approved fire department vehicle access as measured by an unobstructed route around the exterior of the building. Fire Apparatus access roads are required when serving 3 or more residential structures. Fire apparatus access roads for outside storage areas shall be provided in accordance with applicable provisions of the Oregon Fire Code or in accordance with nationally recognized standards, see OFC 503.1.

Fire apparatus access roads shall be provided as required by the Oregon Fire Code and meet the following conditions:

- A. All fire apparatus access roads in excess of 150 feet in length shall be provided with an approved turnaround (see 5.4 of this interpretation & OFC 503.1 and Appendix D.
- B. All fire apparatus access roads shall be at least 20 feet width of firm, uniform all-weather surface capable of supporting gross vehicle weights of 75,000 pounds and minimum wheel load

IFC Chapter 5
Access Roads/Driveways
Approved Date

of 12,500 pounds, a minimum curve radius of 45 feet and have a clear height of 13 feet, 6 inches and be maintained clear of debris/obstructions, see OFC 503.2.1 to 503.2.7 and Appendix D.

- C. Grade for fire apparatus access roads shall not exceed 12 percent with a maximum of 15 percent on short pitches, defined as no more than 200 feet in length. Where there are existing conditions, which exceed these parameters, the Fire Code Official will require additional road improvements and fire protection. These additional measures include paving of the problematic sections of road surface, wider road widths, and/or special fire protection systems, such as approved, monitored smoke detection systems and fire sprinkler systems. In no instance shall a grade exceed 17 percent. Refer to OFC 503.1.1 in considering a variance of this interpretation and the Fire Code, see OFC 503.1, OFC 503.2.7, and Appendix D.

- D. Fire apparatus access roads shall be designed and maintained to support fire apparatus. Roads must sustain a minimum wheel load of 12,500 pounds and gross vehicle load of 75,000 pounds, and must be provided with a firm, uniform all weather driving surface. Written verification of compliance by an Oregon Registered Engineer may be required.

- E. Approved signs and/or notices shall be provided and maintained to identify such roads and prohibit the obstruction thereof. They shall comply with the manual on Uniform Traffic Control Devices, 2001 Edition, see OFC 503.3. "No Parking" and "Fire Lanes" shall be signed and marked as follows:
 - 1. Fire lane markings on curbs or road surface shall be painted bright red with white letters. The stroke shall be 1 inch with letters 6 inches high to read "No Parking - Fire Lane." Spacing for signage shall be every 25 feet.

IFC Chapter 5
Access Roads/Driveways
Approved Date

2. Vertical signs shall be mounted no lower than 4 feet and no higher than 8 feet.
3. Vertical signs shall be 12 inches wide by 18 inches high. Signs shall have red letters and border on a white background. The word "NO" shall be presented in a reversed color arrangement in the upper left hand corner. Spacing shall not exceed every 25 feet.

5.3 DRIVEWAY STANDARDS:

Driveway standards for private roads meet the following conditions:

- A. Driveways shall be built and maintained to provide a minimum 12-foot width of firm, uniform all-weather surface capable of supporting gross vehicle weights of 75,000 pounds and minimum wheel load of 12,500 pounds. Written verification of compliance by an Oregon Registered Engineer may be required. The 20 foot right of way shall consist of a 12 foot firm, uniform all weather travel lane bordered by a 4 foot section on each side which shall be maintained clear of debris and obstructions. Driveways shall have a minimum curve radius of 45 feet and a vertical clearance of 13 feet 6 inches. See OFC 503.2 and Appendix D.
- B. Driveways in excess of 400 feet shall provide 20-foot wide by 40-foot long turnouts at a maximum spacing of $\frac{1}{2}$ the driveway length or 400 feet, whichever is less. Wherever visibility is limited, these distances should be reduced appropriately.
- C. Dead-end-driveways are defined as dead-end roads over 150 feet in length serving a single residence. Dead-end-driveways shall have turnarounds such as a cul-de-sac, hammer head, etc. as shown in diagram, section 5.4, see also OFC 503.2.5 and Appendix D.

IFC Chapter 5
Access Roads/Driveways
Approved Date

- D. Driveway grades shall not exceed 12 percent, with a maximum of 15 percent on short pitches of no more than 200 feet. Where there are existing conditions, which exceed these parameters, the Fire Code Official will require additional road improvements and fire protection. These additional measures include paving of the problematic sections of road surface, wider road widths, and/or special fire protection systems, such as approved, monitored smoke detection systems and fire sprinkler systems. In no instance shall a grade exceed 18 percent. Exception: Current driveways greater than 18% that have a residential structure need not change, unless residential structure is replaced or remodeled more than 50%.
- E. Driveways shall be marked with the residence's address unless the residence or building is in such a position as to be plainly visible from the roadway. The residence or building address must be legible from the street or road fronting the property. Letters or numbers should be a minimum of three inches in height and constructed of reflectorized material or as required by the Columbia County Addressing Ordinance, see OFC 503.3.
- F. If the driveway has a road name it shall be identified with approved signs, see OFC 503.3.

5.4 TURNAROUNDS: (Pertains to both Access Roads and Driveways)

Turnarounds, cul-de-sacs, and other turnaround configurations shall be provided as required by the Oregon Fire Code 503.2 and Appendix D, and meet the following conditions (refer to diagrams page 6):

- A. Maintain unobstructed clearance for bumper overhang on right-of-ways.
- B. Curb height not to exceed 6 inches.
- C. No-parking areas shall be designated by the Fire

IFC Chapter 5
Access Roads/Driveways
Approved Date

Code Official and comply with the manual of Uniform Traffic Control Devices, 2001 Edition. If curbs are not present "No Parking" signs shall be used.

- D. "No Parking - Fire Lane" sign locations will be determined by the Fire Code Official and comply with the manual of Uniform Traffic Control Devices, 2001 Edition.
- E. The structural section of the road shall be designed to support 75,000 pounds of vehicle weight, 12,500 pounds wheel load. Written verification of compliance by an Oregon Registered Engineer may be required.
- F. Drainage shall be required to prevent ponding.
- G. The area of the turnarounds shall be permanently maintained, kept clear, and unobstructed at all times. Signage may be required.
- H. The creation of the turnarounds shown in this interpretation at any specific site must be approved by the Fire Code Official, an Oregon Registered Professional Engineer and the Planning Department on apparatus access roads. On driveways the Fire Code Official shall approve all proposed turnarounds.

5.5 EMERGENCY ACCESS:

- A. More than one fire apparatus road shall be provided where emergency evacuation and emergency operations could be impaired by vehicle congestion, condition of terrain, climatic conditions or other factors that could limit access and evacuation. OFC 503.1.2 and Appendix D. Wherever possible, developments must provide two means of access to and from site when serving thirty or more units. (A duplex counts as two units, etc.) When two means of access cannot be installed due to topography, waterways, non-negotiable grades or other similar conditions,

IFC Chapter 5
Access Roads/Driveways
Approved Date

the chief is authorized to require additional fire protection as specified in OFC Section 503.1.1 and Appendix D, or other alternatives such as medians, gated emergency roads, etc.

- B. When security gates and openings to or within a structure or an area is unduly difficult because of secured openings or where immediate access is necessary for life-saving or fire-fighting purposes, the Fire Code Official may require a key box to be installed in an accessible location. The key box shall be a type approved by the Fire Code Official and shall contain keys, codes, or other devices to gain necessary access as required by the Fire Code Official, see OFC 503.5 and 503.6.

5.6 Bridges, Culverts, Gates and other structures

- A. Bridges, culverts, and other structures in the roadbed shall be constructed and maintained to support gross vehicle weights of 75,000 pounds and appropriate wheel loading. When a bridge is involved in the construction of a fire apparatus road access or driveway, it shall be designed and certified by an Oregon Registered Professional Engineer that it meets or exceeds the gross vehicle weights of 75,000 pounds and appropriate wheel loading.
- B. Bridges serving five (5) or fewer residents may be constructed to a minimum width of 12 feet. Handrails and curbs are required on all bridges. Bridges serving six (6) or more residents shall meet Columbia County Bridge standards for public roads.
- C. An Oregon License Bridge Inspector shall inspect Bridges every five (5) years. In the event a bridge is in despair an inspection is required annually.

IFC Chapter 5
Access Roads/Driveways
Approved Date

- D. The installation of a gate for a driveway or apparatus access way shall meet the following:
1. The minimum gate width shall be 12 feet for driveways and 20 feet for apparatus access way.
 2. Gates shall be of the swinging or sliding type.
 3. Construction of gates shall be of materials that allow manual operation by one person.
 4. Gate components shall be maintained in an operative condition at all times and replaced or repaired when defective.
 5. Electric gates shall be equipped with a means of opening the gate by fire department personnel for emergency access. Emergency opening devices shall be approved by the fire code official.
 6. Manual opening gates shall not be locked with a padlock or chain and padlock unless they are capable of being opened by means of forcible entry tools.
 7. Locking device specifications shall be submitted for approval by the fire code official.
- E. Side slopes will be no steeper than 1.5 feet in run to 1 foot rise. Anything steeper than this must meet OSSC provisions for retainment or be certified by a certified geotechnician for soil stability.

5.7 PLANS AND SPECIFICATIONS:

Plans for fire apparatus access roads/driveways shall be reviewed by the applicable Rural Fire District for all access roads and driveways in the area corresponding to their respective Ambulance Service Area in accordance with the Oregon Fire Code 501.3. These plans shall contain all of the following information:

- A. Right-of-way width
- B. Width of all-weather surface
- C. Turnouts

IFC Chapter 5
Access Roads/Driveways
Approved Date

- D. Turnarounds
- E. Grades (percent)
- F. Curves (radius)
- G. Bridges
- H. Culverts
- I. Structures in relation to roadways
- J. Addressing (if known)
- K. Intersections
- L. Existing structures & driveways on roadway
- M. Location of hydrants/hydrant reflectors if required

5.8 INSPECTION FOR COMPLIANCE

In order to insure that access roads/driveways are improved to the required standards, an inspection form must be signed by a Fire District official signifying approved temporary access before a building permit is issued. This will assure that road improvements are adequate for fire protection equipment to reach the site during the construction phase. A final sign-off will be required prior to final occupancy by the applicant to ensure continued access throughout the existence of the structure(s), see OFC 501.3 and 501.4 and Appendix D.

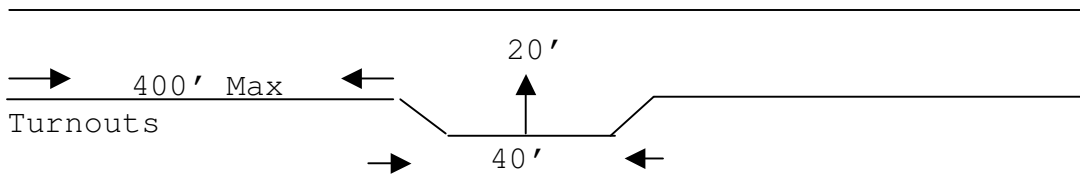
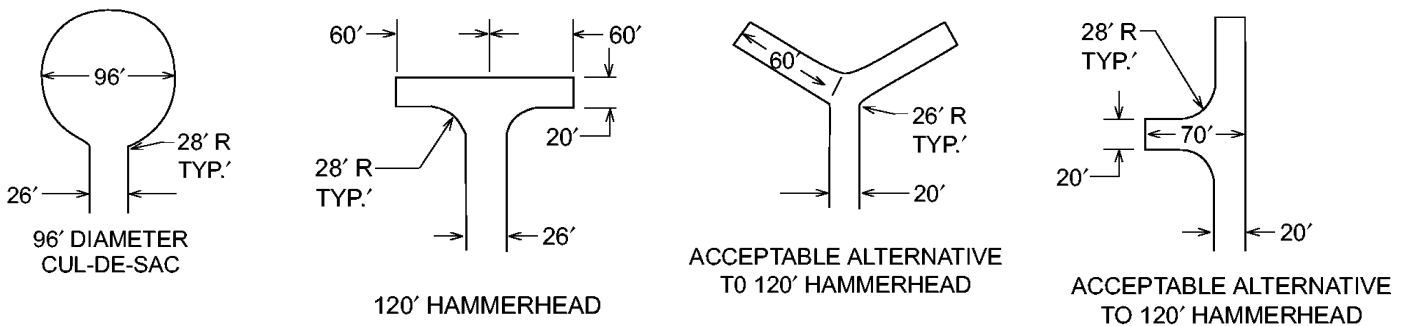

FIRE SERVICE IMPROVEMENT REQUIREMENTS
FOR ROADS OVER 150 FEET IN LENGTH WITH
ONE AND TWO FAMILY DWELLINGS

If this is a new access connecting to a county road, please contact the Columbia County Department of Land Development Services to obtain a road approach permit or a sign-off indicating that no permit is required.

The Oregon Fire Code, Section 501.3 and the Zoning and Development Ordinance of Columbia County, Oregon, require roadway/driveway improvements to a construction or mobile home installation site prior to the issuance of a building permit. One reason for this requirement is to assure that road improvements will allow fire protection equipment to reach the site, not only during the construction phase but throughout the existence of the structure. In order to assure that the access road meets the required standards, **this form must be signed by a local Fire Service official, and a copy of the signed form must be attached to your application for a dwelling, construction or mobile home placement permit.**

Minimum standard roadway approval requires a twelve-foot (12') wide, uniform all-weather travel lane, with a twenty foot (20') right-of-way maintained clear of debris and obstructions three feet (4') on each side of the travel lane. Driveways shall sustain a minimum wheel load of twelve-thousand five-hundred (12,500) pounds per wheel and a gross vehicle load of seventy-five thousand (75,000) pounds. Turnouts twenty feet wide (20') and forty feet (40') long may be required on any driveways exceeding four-hundred feet (400') in length. The unobstructed width must be maintained for not less than twenty feet (20'). Vertical clearance shall be maintained at no less than thirteen feet, six inches (13'6"). All access roads and driveways over one hundred-fifty feet (150') in length shall be provided with a turnaround area at or near the end, improved to the above standards and of a design approved by the local Fire Service. Proper drainage must be provided. Bridges and culverts shall be capable of supporting a minimum of seventy-five thousand (75,000) pounds. Average road grade shall not exceed twelve percent (12%) and no grade shall exceed fifteen percent (15%). Maximum curve centerline shall be not less than forty-five feet (45') radius. Any new access connecting to a Columbia County road requires a Columbia County Entrance Permit.

Please deliver this form to the local Fire Service and assist them in locating and inspecting the roadway/driveway providing access to the proposed development site. Maps to assist you in this effort may be obtained from the Columbia County Assessor's office or the Columbia County Department of Land Development Planning.

TYPE AND LOCATION OF PROPOSED DEVELOPMENT:

Name: _____ Phone: _____ Tax Lot:

Address:

Description:

-----**THIS SECTION TO BE COMPLETED BY FIRE SERVICE**-----

- _____ I have inspected the plot plan for the above location and proposed road improvements. The roadway may be built as proposed.

- _____ I have inspected the above property and have determined that road improvements are adequate for temporary access by Fire Service equipment. A re-inspection must take place prior to occupancy.

- _____ I have inspected the above property and determined that road improvements to the proposed development site are suitable for access by Fire Service equipment.

_____ The following improvements must be completed prior to permit issuance:

Name: _____ Date:

Fire Service: _____ Date:

White Copy - Fire District

Canary Copy - Planning/Building Department

Pink Copy - Applicant